

TECHNICAL DETAILS

90x290x590 Rock Stretcher

PRODUCT DRAWINGS

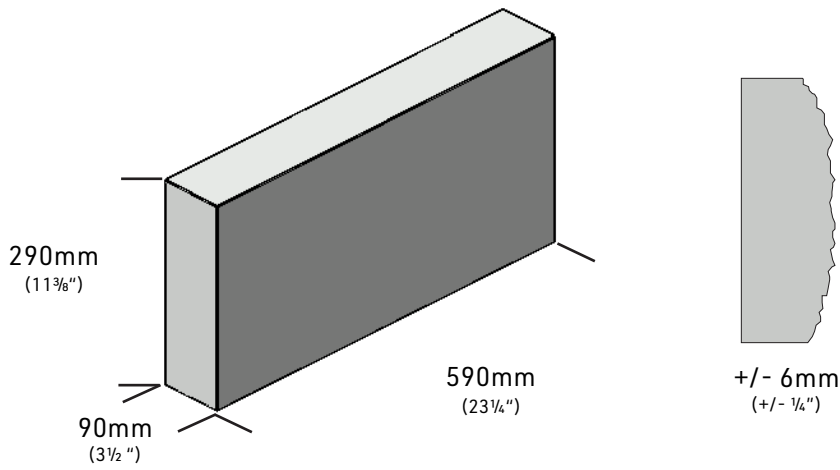

PRODUCT DETAILS

	90x290x590 Rock Stretcher		90x290x390 Rock Corner	
	Metric	Imperial	Metric	Imperial
Selling UoM		EA		EA
Units/Skid	32EA	32EA	60EA	60EA
Weight/Each	36.9kg	81.09lbs	24.5kg	54lbs
Weight/Skid	1,198kg	2,791lbs	1,491kg	3,280lbs
# of Layers	2	2	2	2
Pieces/Layer	16	16	30	30
Coverage/Unit	0.186m ²	2sf	0.124m ²	1.33sf
Coverage/Skid	5.95m ²	64sf	7.41m ²	79.8sf
Linear Unit/Piece	0.30m	0.98lf	0.30m	0.98lf
Pallet Size	101cmx119cm	40"x47"	101cmx119cm	40"x47"

CORNERS

Corner units are sold seperately.

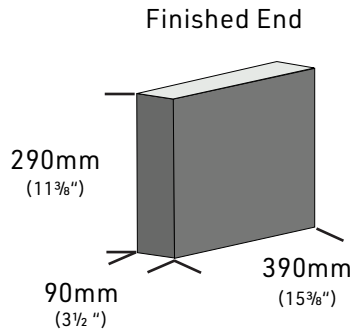

TYPICAL INSTALLATION PATTERN

Running Bond

Stack Bond

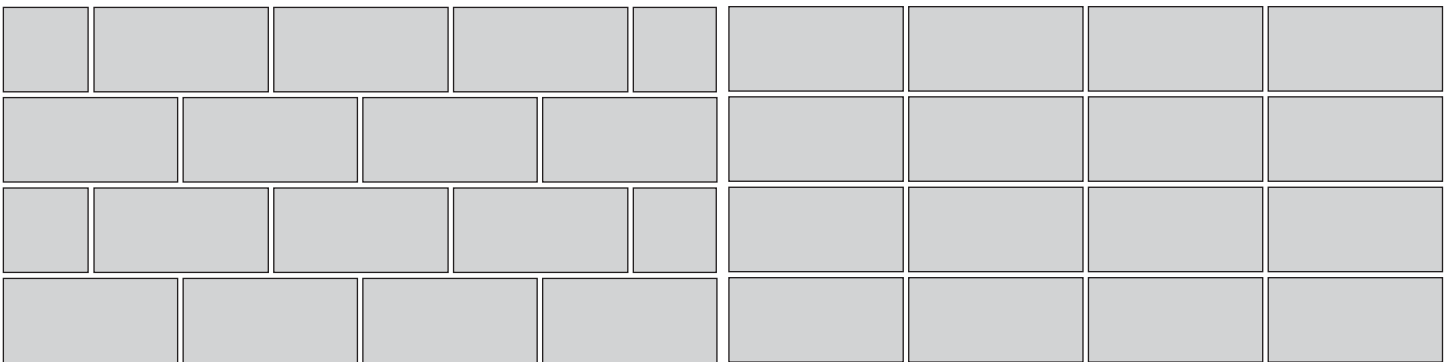

Typical Installation Guidelines: • Blend product from multiple packages for most natural look

TYPICAL MORTAR JOINT

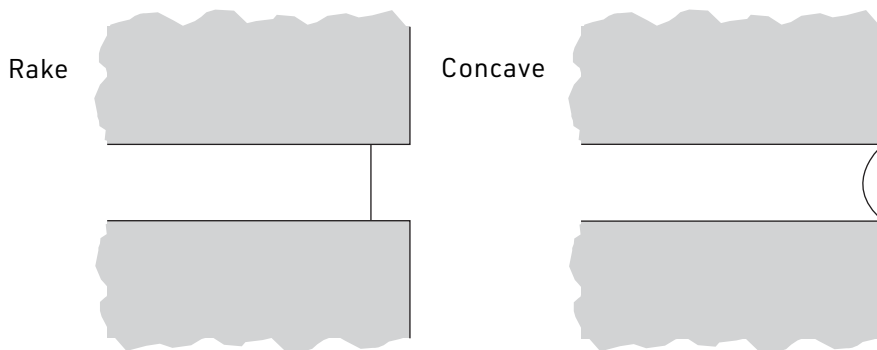

Recomended Mortar Joint 10mm (³/₈")

TYPICAL COURSING GUIDE

Tables Include one unit and one joint.

Vertical Units	10mm Joint	3/8" Joint	Horizontal Units	10mm Joint	3/8" Joint
1	300mm	15 ³ / ₄ "	1	600mm	23 ⁵ / ₈ "
2	600mm	31 ¹ / ₂ "	2	1,200mm	47 ¹ / ₄ "
3	900mm	47 ¹ / ₄ "	3	1,800mm	70 ³ / ₄ "
4	1,200mm	62 ⁷ / ₈ "	4	2,400mm	94 ³ / ₈ "
5	1,500mm	78 ⁵ / ₈ "	5	3,000mm	118"
6	1,800mm	94 ³ / ₈ "	6	3,600mm	141 ⁵ / ₈ "
7	2,100mm	110 ¹ / ₈ "	7	4,200mm	165 ¹ / ₄ "
8	2,400mm	125 ⁷ / ₈ "	8	4,800mm	188 ⁷ / ₈ "
9	2,700mm	141 ¹ / ₂ "	9	5,400mm	212 ³ / ₈ "
10	3,000mm	157 ¹ / ₄ "	10	6,000mm	236"
20	6,000mm	314 ⁵ / ₈ "	20	12,000mm	472"
30	9,000mm	471 ⁷ / ₈ "	30	18,000mm	708 ¹ / ₈ "
40	12,000mm	629 ¹ / ₈ "	40	24,000mm	944 ¹ / ₈ "
50	15,000mm	786 ¹ / ₂ "	50	30,000mm	1,180 ¹ / ₈ "
100	30,000mm	1,572 ⁷ / ₈ "	100	60,000mm	2,360 ³ / ₈ "

CODES & STANDARDS

Shouldice Stone Products are supported by the following National Codes & Standards. Refer to local building codes and standards to confirm best practice.

CANADIAN

[CSA A165 Standards on Concrete Masonry Units](#)

[CSA A371 Masonry Construction for Buildings](#)

[CSA A179 Mortar and Grout for Unit Masonry](#)

[CSA A370 Connectors for Masonry](#)

AMERICAN

[ASTM C55 Specification for Concrete Building Brick](#)

[ASTM C90 Specification for Loadbearing Concrete Masonry Units](#)

[ASTM C270 Specification for Mortar for Unit Masonry](#)

[ASTM C476 Specification for Grout for Masonry](#)

[ASTM C1634 Specification for Concrete Facing Brick and Other Concrete Masonry Facing Units](#)

[NCMA TEK 8-4A Cleaning Concrete Masonry](#)

[NCMA TEK 9-1A Mortars for Concrete Masonry](#)

[NCMA TEK 8-3A Control and Removal of Efflorescence](#)

[NCMA TEK 10-4 Crack Control for Concrete Brick and other Concrete Masonry Veneers](#)

[NCMA TEK 19-5A Flashing Details for Concrete Masonry Walls](#)

TYPICAL UNIT PROPERTIES

Products exceed the CSA and ASTM standards.

	Standard	Compression Strength	Absorption	Density	Fire Rate (Hours)
CSA	A165.1	>15mpa	<8%	>2000kg/m ²	1.4
ASTM	C1634	>3000psi	<12lb/ft ³	>125lb/ft ³	

HATCH PATTERNS & TEXTURE MAPS

To access Shouldice Stone Hatch Patterns and texture maps visit the corresponding [shouldice.ca product page](#) for current availability.

CONTACT US

For technical questions regarding our product line please contact our knowledgeable customer service team. By phone: **800.265.3174** or email: **designer@shouldice.ca**